

Cyan electroluminescence from *n*-ZnO/*i*-CdZnO/*p*-Si heterojunction diodes

Lin Li, Zheng Yang and Jianlin Liu

Quantum Structures Laboratory, Department of Electrical Engineering, University of California, Riverside, California 92521, USA

ABSTRACT

n-ZnO/*i*-CdZnO thin film was grown on *p*-type Si substrate by plasma-assisted molecular-beam epitaxy (MBE). Rectifying *I*-*V* curves show typical diode characteristics. Cyan electroluminescence emissions at around 473 nm were observed when the diodes were forward-biased at room temperature. The emission intensity increases with the increase of the injection current. Room temperature photoluminescence verifies the electroluminescence emissions come from CdZnO layer.

INTRODUCTION

ZnO is a promising optoelectronic material for light emitting devices in ultraviolet and visible wavelength [1] because of its large wide direct band gap of 3.3 eV at room temperature and large exciton binding energy of 60meV. The bandgap of ZnO can be extended wider by alloying with MgO [2], while it can also be adjusted narrower to 1.8 eV by alloying with CdO [3-6]. This property makes ZnO based light sources emitting light from ultraviolet region to green band or even further. However, reliable *p*-type ZnO with high carrier concentration has always been an issue for ZnO light emitting devices application. Here, we demonstrate ZnO based double heterojunction LED devices using *p*-type Si as *p*-layer, with inserted CdZnO as active layer. Visible cyan emissions were observed and studied.

EXPERIMENT

ZnO based heterojunction diodes were grown by plasma-assisted MBE on *p*-type (1–10Ωcm) Si (100) substrates. Elemental Zn (6N), Cd (6N), Ga (6N) were heated by effusion cells and used as metal sources. Oxygen (5N) plasma generated by a radiofrequency plasma generator was used as the oxygen source. Fig. 1 shows the structure of the sample. A 100 nm CdZnO layer was first deposited at 150 °C on *p*-type Si(100) substrate, followed by 800 °C in situ annealing for 5 min under vacuum, then a 350 nm Ga-doped ZnO layer was deposited at 500 °C as *n*-type layer. Room temperature (RT) PL measurements were carried out using a home-built PL system, with a 325-nm He-Cd laser as excitation source and a photomultiplier tube behind the monochromator as detector. Samples were etched by diluted hydrochloride acid to different depth to investigate the PL emission from different layers. Heterojunction diodes were fabricated by standard photolithography techniques. Etching was done using diluted hydrochloride acid to reach down to the substrate. Mesas with size of 800μm×800μm were formed on the samples. Metal contacts were deposited by E-beam evaporator. Au/Ti contacts with thicknesses of 200/10nm were used for contacts of both Ga-doped ZnO and *p*-type Si. The contacts were subjected to rapid thermal annealing (RTA) under nitrogen ambient at 600 °C for 60 seconds to form ohmic contacts. Current-voltage (*I*-*V*) characteristics were measured using Agilent 4155C

semiconductor parameter analyzer. EL measurements were carried out in the same system as PL measurement.

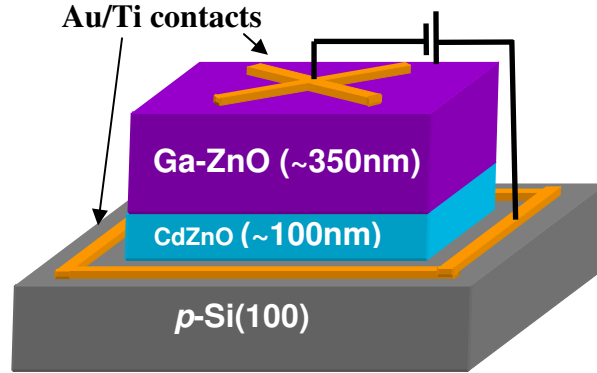

FIG. 1. (color online) Device structure of the sample: Ga-doped ZnO/CdZnO/p-Si.

DISCUSSION

To study the optical properties of Ga-doped ZnO layer and CdZnO layer, Room temperature (RT) PL measurements of each layer were studied. PL measurement of Ga-ZnO layer was carried out from the surface of the sample, while another piece of sample was etched to about 100 nm from substrate to investigate the PL emission of CdZnO layer. As shown in Fig. 2, the PL emission of Ga-doped ZnO layer shows strong and sharp ZnO near band edge (NBE) emission at around 380 nm, although there is deep level emission centered around 522 nm, which comes from the defects. On the other hand, the RT PL emission of CdZnO layer is dominated by the NBE emission of CdZnO at around 451 nm (2.75 eV). There is also a very weak emission peak at 382 nm (3.25 eV), which comes from residual GaZnO in the etched sample.

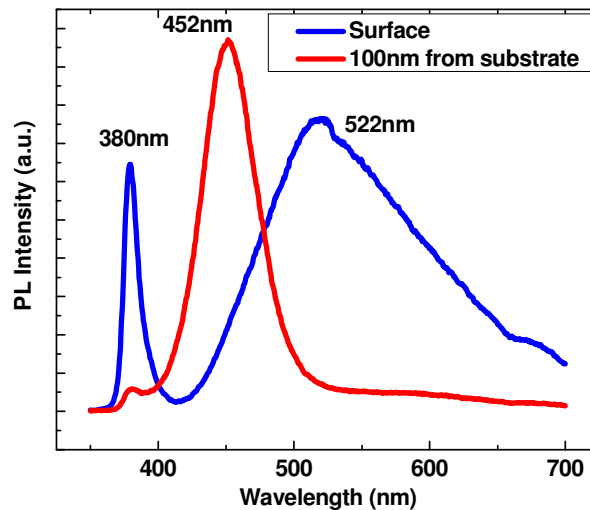

FIG. 2. (color online) Room temperature PL of the sample from surface (blue line) and 100nm from substrate (i.e. CdZnO layer) (red line) respectively.

Fig. 3 shows the I - V curve of the fabricated LED device with the voltage configuration as shown in Fig. 1. It shows typical diode characteristic under forward bias. The inset shows the

Ohmic behavior of n-n contacts and p-p contacts. The energy band diagram of the sample is presented in Fig. 4. The room temperature PL maximum position is approximately used as the band gap of CdZnO layer, which is about 2.74 eV. The Cd concentration is calculated using the relation $E_g(x) = 3.37 - 2.82x + 0.95x^2$ from Ref. 7. And x is calculated to be 0.24. The electron affinity of CdZnO layer is assumed to be linear distributed between 4.3 eV (ZnO) and 4.5 eV (CdO) [8, 9]. Thus it results in 4.35 eV. So there is a 0.05 eV difference in electron affinity between CdZnO layer and Ga-doped ZnO layer on the top. The electron affinity between ZnO and Si substrate is 0.3 eV [10], so a 0.35 eV electron affinity is observed at the CdZnO/Si interface. Therefore, a double heterojunction is formed clearly as shown in the band alignment. Room temperature EL spectra of the sample at different injection current are shown in Fig. 5. The room temperature EL emissions are dominated by the NBE emission from CdZnO active layer at around 473 nm, which corresponds to the room temperature PL emission from CdZnO layer. The difference between PL and EL peak positions may come from the non-uniformity of the CdZnO layer and heat induced bandgap shrinkage under the high injection currents. There is also a weaker shoulder at around 405nm in each injection current; it may come from the Cd weak phase near the CdZnO/Ga-doped ZnO interface.

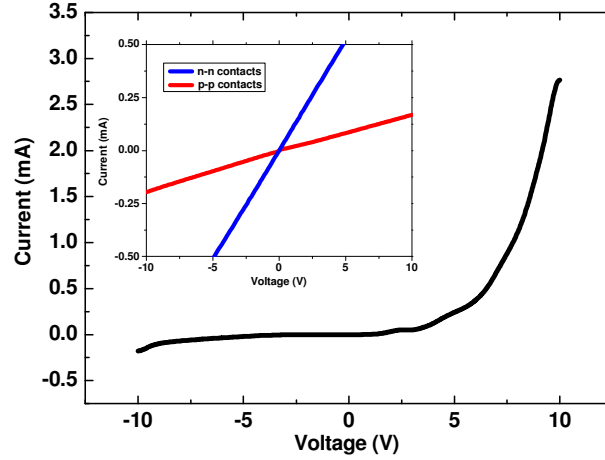

FIG. 3. (color online) I - V characteristics of the sample, with voltage configurations as shown in Fig 1, which shows typical rectifying characteristics.

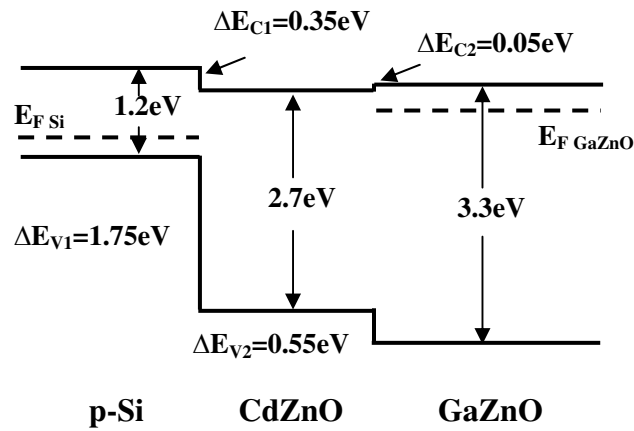

FIG. 4. Band alignment structure of the sample.

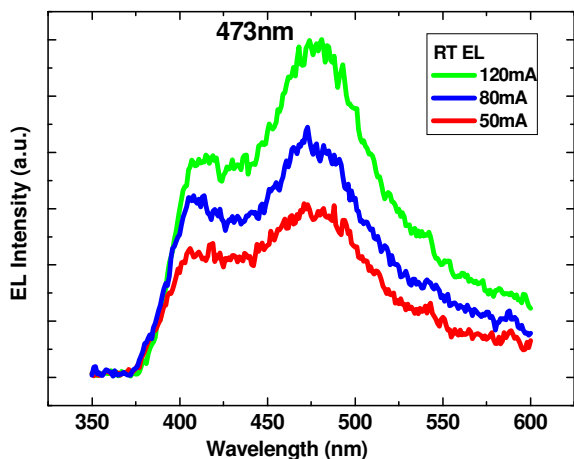

FIG. 5. (color online) Room temperature EL characteristics of the sample under different injection currents.

CONCLUSIONS

ZnO based heterojunction using Ga-doped ZnO as *n*-layer, CdZnO as an active layer, and *p*-type Si substrate as *p*-layer was grown by MBE. Dominant cyan EL emissions were observed at RT. RT PL measurements at different thicknesses and temperature dependent EL confirmed that these emissions come from the radiative recombinations in CdZnO active layers in the film. ZnO based cyan emitting LED devices are demonstrated.

ACKNOWLEDGMENTS

This work was supported by DOE (DE-FG02-08ER46520) and NSF (ECCS-0900978).

REFERENCES

1. D. C. Look, Mater. Sci. Eng., B **80**, 383 (2001).
2. A. Ohtomo, M. Kawasaki, T. Koida, K. Masubuchi, H. Koinuma, Y. Sakurai and Y. Yoshida, T. Yasuda and Y. Segawa, Appl. Phys. Lett. **72**, 2466 (1998).
3. T. Makino, Y. Segawa, M. Kawasaki, A. Ohtomo, R. Shiroki, K. Tamura, T. Yasuda, and H. Koinuma, Appl. Phys. Lett. **78**, 1237 (2001).
4. S. Shigemori, A. Nakamura, J. Ishihara, T. Aoki, and J. Temmyo, Jpn. J. Appl. Phys. **43**, L1088 (2004).
5. S. Sadofev, S. Blumstengel, J. Cui, J. Puls, S. Rogaschewski, P. Schafer, and F. Henneberger, Appl. Phys. Lett. **89**, 201907 (2006).
6. Z. Yang, L. Li, Z. Zuo, and J. L. Liu, J. Cryst. Growth, (in press).
7. X. J. Wang, I. A. Buyanova, W. M. Chen, M. Izadifard, S. Rawal, D. P. Norton, S. J. Pearton, A. Osinsky, J. W. Dong, and A. Dabiran, Appl. Phys. Lett. **89**, 151909 (2006).
8. A. Nakamura, T. Ohashi, K. Yamamoto, J. Ishihara, T. Aoki, J. Temmyo and H. Gotoh, Appl. Phys. Lett. **90**, 093512 (2007).
9. R. Ferro and J. A. Rodríguez, Sol. Energy Mater. Sol. Cells **64**, 363 (2000)

10. L. J. Mandalapu, Z. Yang, F. X. Xiu, D. T. Zhao, and J. L. Liu, *Appl. Phys. Lett.* 88, 112108 (2006).